

CAD FILE:

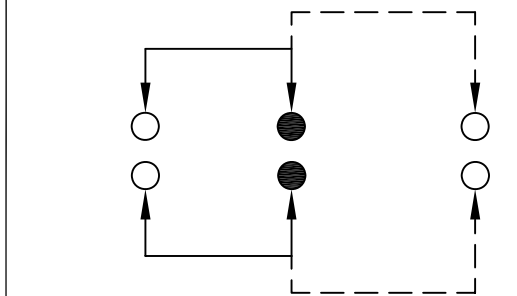

SCHEMATIC (NON-SHORTING)

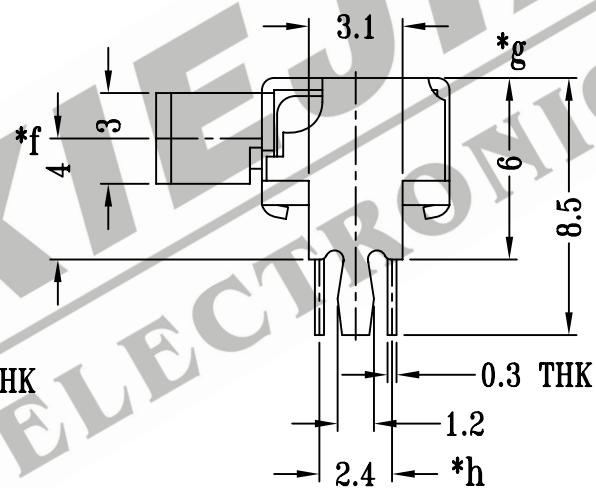
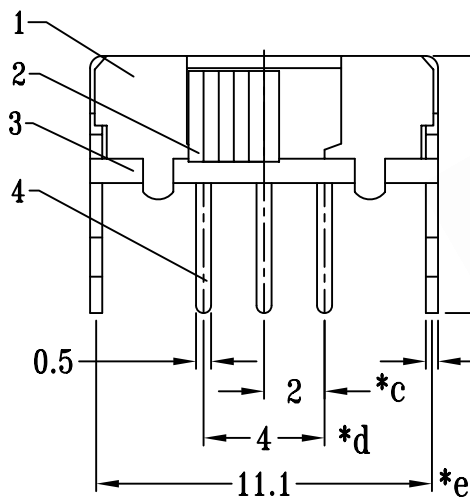
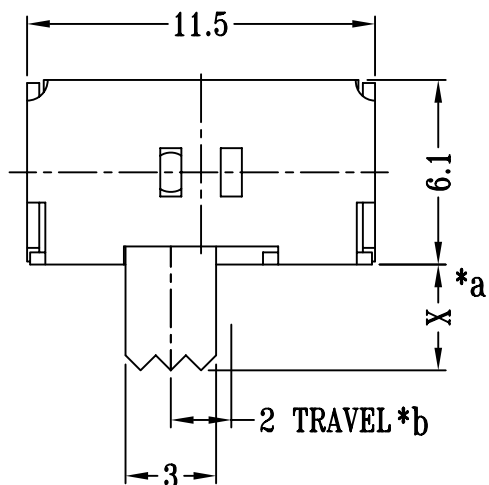
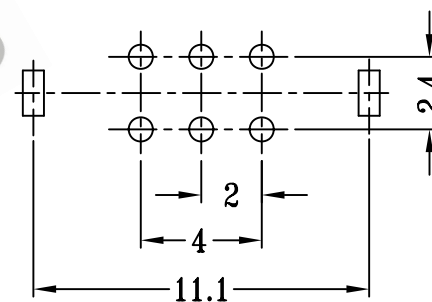

P.C.B LAYOUT

注:带"*"表示关键尺寸(8个)

8					TOLERANCE UNLESS SPECIFIED	SHENZHEN XIEJIA ELECTRONICS CO.,LTD.				
7										
6	CONTACT CLIP	PBS	2	Ag CLAD	WITHIN: 1.5±0.1mm	ISSUE	DATE	DESCRIPTIONS OF REVISION		APPD.
5	SPRING PLATE	STAINLESS STEEL	1	NATURAL	OVER: 1.5±0.2mm					
4	TERMINAL	BRASS STRIP	6	Ag PLATED OVER Ni PLATED	TITLE : HORIZONTAL SLIDE SWITCH	UNIT : mm		DRWG NO.: XJ-DR-SK22D36-00		
3	BASE	PHENOLIC RESIN	1	NATURAL	MODEL: SK-22D36	SCALE: 4:1		DWN.	ZHOUYU	2004-12-9
2	KNOB	POM	1	BLACK				CHK'D	FANGYING	2004-12-9
1	FRAME	STEEL STRIP	1	Sn PLATED	ALL MATERIALS MUST BE COMPLIANT TO ROHS			APPD.	KANGXINAN	2004-12-9
NO.	PARTS	MATERIALS	Q'TY	FINISH						